

VISION PROFILE CYLINDER



Profile cylinder for Vision handles. The profile half cylinder is certified according to DIN EN 1303 and DIN 18252. There are lengths of 40 and 45 mm, it is made of brass with a 360° cam and it is adjustable in 8 increments of 45° (8-position adjustability).

The cylinder is delivered with three keys.



RELATED PRODUCTS

Similar products: 1-210

Use the Index Code at industrilas.com

TECHNICAL INFORMATION

For full system description of cylinder and key technology, see Technical specification below the product table.

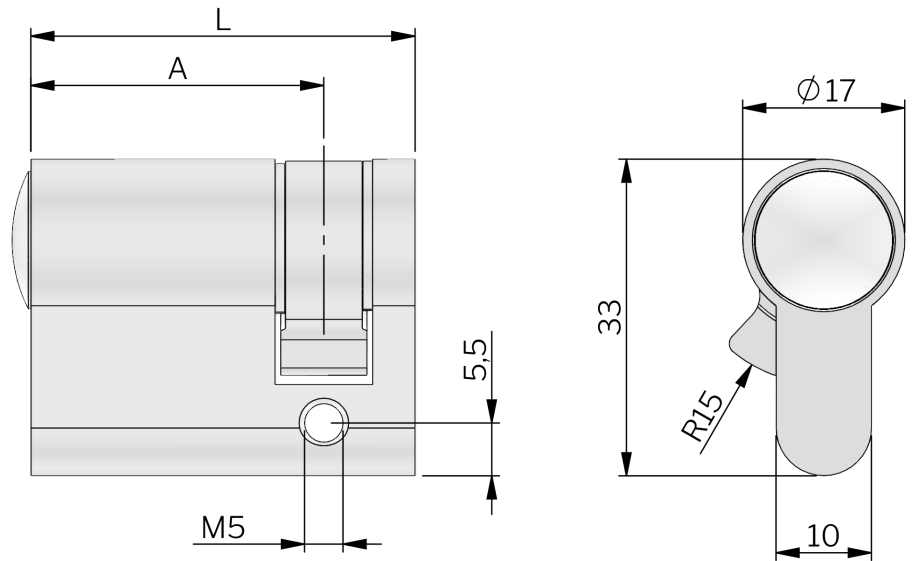

celator

P/N	Description	Cylinder	Length
511058-1002	Profile cylinder, keyed alike	Keyed alike IL4711	40 mm
511058-1002-01	Spare key, keyed alike	Keyed alike IL4711	-
511058-1004	Profile cylinder, keyed alike	Keyed alike IL4712	40 mm
511058-1005	Profile cylinder, keyed alike	Keyed alike IL4713	40 mm
511058-1006	Profile cylinder, keyed alike	Keyed alike IL4714	40 mm
511058-1007	Profile cylinder, keyed alike	Keyed alike IL4715	40 mm
511058-1008	Profile cylinder, keyed alike	Keyed alike IL4716	40 mm
511058-1009	Profile cylinder, keyed alike	Keyed alike IL4717	40 mm
511058-1010	Profile cylinder, keyed alike	Keyed alike IL4718	40 mm
511058-1011	Profile cylinder, keyed alike	Keyed alike IL4719	40 mm
511058-1012	Profile cylinder, keyed alike	Keyed alike IL4720	40 mm
511058-1020	Profile cylinder, keyed alike	Keyed alike IL4710	40 mm
511059-1002	Profile cylinder, keyed to differ	Keyed to differ	40 mm
511158-1000	Profile cylinder, keyed alike	Keyed alike IL4711	45 mm
511159-1000	Profile cylinder, keyed to differ	Keyed to differ	45 mm

Technical specifications

System description of cylinder / key technology

- Locking side has 5 spring-loaded, solid tumblers, axially arranged.
- Consists of 10 sectionally arranged core- and body pins with "waist".
- Solid pin tumblers with a minimum diameter of 3 mm, made from tempered bronze/steel.
- Nickel plated hardened steel core pins and housing pins.
- One-piece solid brass cylinder housing, with a multi-layer galvanized surface treatment for higher corrosion protection.
- One-piece solid brass cylinder core with a minimum diameter of 13 mm.
- Convex core head with guide funnel and core head groove for positive torque-transfer when opening and closing.
- Supplied with 3 reversible keys from nickel-silver for added corrosion- and wear-resistance.
- Horizontal keyhole.
- Cam adjustable in increments of 45° and made from one piece of sintered steel.
- Spare parts available for min. 25 years.

Other systems available on request

- Locking Type Z / ZHS / HS / GHS with security card.
- Coded individual locking with security card.
- Locking systems VdS 2156 class A, B, B+ possible.
- Systems with technical copy protection, mobile elements in the key, optionally with increased drilling- and/or impact- and pulling protection.
- Profile double cylinder with and without knob, cam cylinders, padlocks, mechatronic or electromechanical locking system.